

PROGRAMMING MANUAL

KOBALTO



English

Code: P285U00

Date: 05 - 2007

INTRODUCTION

This “Programming Manual” is a very useful tool for those operators who want to get the most out of the potential of the installed software and know in detail all of the software available functions. This document is available in PDF format in the Reserved Area of our internet site www.nwglobalvending.com or, on request, through our after-sales service.

The Manual is divided into 2 parts:

The First Part contains the information concerning the Filler Menu.

The Second Part contains the information concerning the Technician Menu.



The operations described can modify the functioning cycles, therefore they must be carried out only by personnel who have the specific knowledge of the machine functioning from a point of view of electrical safety and health regulations.

INTRODUCTION

The machines can function in 3 different operating modes:

- **Normal Vending**
- **Filler Menu**
- **Technician Menu**

NORMAL VENDING MODE

In Normal Vending mode it is possible to perform some operations with the door closed, keeping pressed the wash button “” for more than 2 seconds or the “” button (see figure) if the wash button is not present. The push-buttons take on numeric values as shown in the figure:

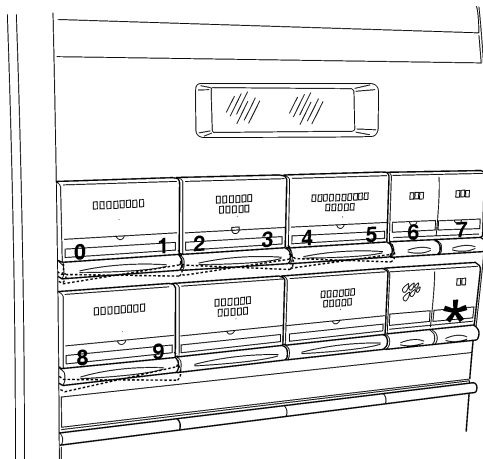

The machine waits a few seconds for the entry of a 5-digit code that will allow the following operations if enabled in the Password option within the Technician Menu:

- Reset counters
- Jug Facility
- Free Vending
- Keypad lock
- Wash
- Test selections
- Filter reset
- Waste tray reset

By default all passwords are disabled.

PROGRAMMING MENU

In order to access the programming menu, open the front door of the vending machine, switch on the machine and insert the yellow key supplied in the relevant slot located on the left-hand side of the machine.

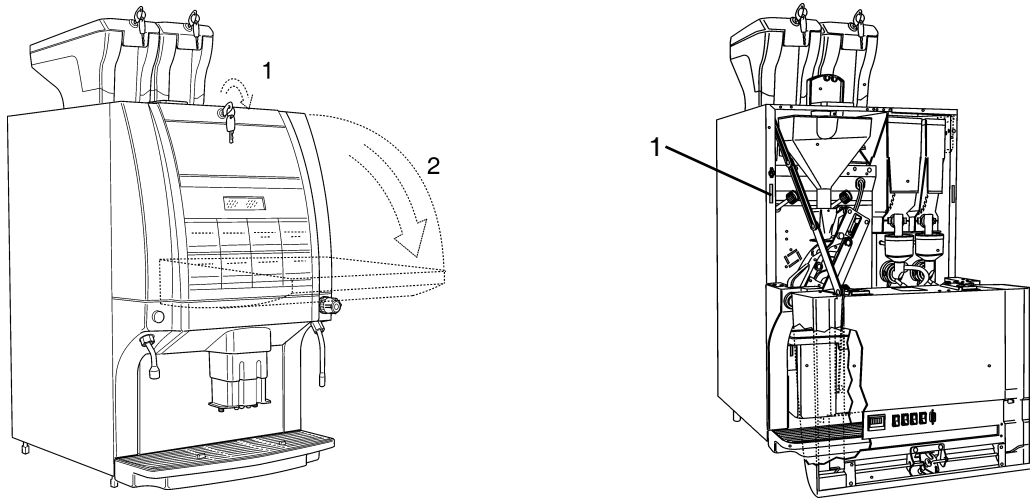

Press the programming access button as shown in the figure:

The machine goes into “Filler Menu” mode.

The buttons shown in the figure are used for surfing through the different menus:

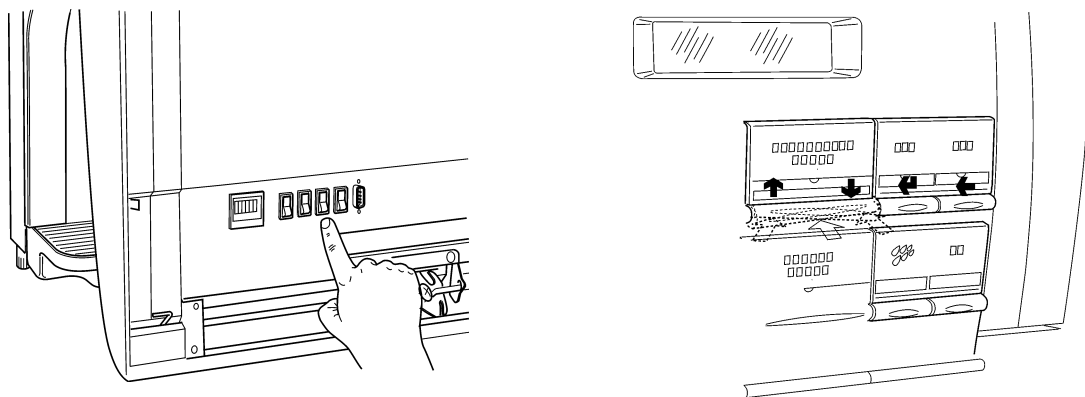

Scrolling buttons UP “↑” and DOWN “↓”

The UP and DOWN scrolling buttons are used for moving from one programming menu item to the next one, located in the same level, and at the same time change the status or the numeric value of the corresponding functions.

Confirm / enter button “↵”

The confirm / enter button is used for moving to the lower level or for confirming a value after being entered or changed.

Exit button “←”

The exit button is used for returning to the higher level or for exiting a change field of a function. When reaching the highest level in the menu, this button is pressed for going from the Technician menu into the Filler menu and vice versa.

FILLER MENU

1 - STATISTICS

1 **STATISTICS**

1.1 - STATIS. PRINTING

1.1 **PRINTING THE STATISTICS**

1.1.1 - PARTIAL PRINTING

1.1.1 **PARTIAL PRINTOUT**

1.1.1.1 - SEL. CNT. PRINT.

1.1.1.1 **PRINTING THE SELECTION COUNTERS** When confirming this function, the counters regarding the different selections are printed.

1.1.1.2 - PRINT BAND CNT

1.1.1.2 **PRINTING THE TIME BAND COUNTERS** When confirming this function, the counters regarding the different time bands are printed.

1.1.1.3 - DISC. CNT.PRINT.

1.1.1.3 **PRINTING THE DISCOUNT COUNTERS** When confirming this function, the counters regarding discounts and overprice are printed.

1.1.1.4 - FAIL. CNT.PRINT.

1.1.1.4 **PRINTING THE FAILURE COUNTERS** When confirming this function, the counters regarding the different failure are printed.

1.1.1.5 - COIN MECH. PRINT

1.1.1.5 **PRINTING THE COIN MECHANISM DATA** When confirming this function, the counters regarding the coin mechanism data are printed.

FILLER MENU

1.1.2 - TOTAL PRINTING

1.1.2

TOTAL PRINTOUT

When confirming this function, all statistics are printed.

1.2 - PRINT REL. STAT.

1.2

PRINTING THE RELATIVE STATISTICS

1.2.1 - PARTIAL PRINTING

1.2.1

PARTIAL PRINTOUT

1.2.1.1 - SEL. CNT. PRINT.

1.2.1.1

PRINTING THE SELECTION COUNTERS

When confirming this function, the relative counters regarding the different selections are printed.

1.2.1.2 - PRINT BAND CNT

1.2.1.2

PRINTING THE TIME BAND COUNTERS

When confirming this function, the relative counters regarding the different time bands are printed.

1.2.1.3 - DISC. CNT.PRINT.

1.2.1.3

PRINTING THE DISCOUNT COUNTERS

When confirming this function, the relative counters regarding discounts and overprice are printed.

1.2.1.4 - FAIL. CNT.PRINT.

1.2.1.4

PRINTING THE FAILURE COUNTERS

When confirming this function, the relative counters regarding failures are printed.

1.2.1.5 - COIN MECH. PRINT

1.2.1.5

PRINTING THE COIN MECHANISM DATA

When confirming this function, the relative counters regarding the coin mechanism data are printed.

FILLER MENU

1.2.2 - TOTAL PRINTING

1.2.2

TOTAL PRINTOUT

When confirming this function, all relative statistics are printed.

1.3 - STATIST. DISPLAY

1.3

DISPLAYING THE STATISTICS

1.3.1 - SEL. CNT. DISP.

1.3.1

DISPLAYING THE SELECTION COUNTERS

1.3.1.1 - CNT DIS. X 5.SEL

1.3.1.1

DISPLAYING THE SINGLE COUNTERS

This function is used for displaying the counters regarding each selection, divided by price band (0, 1, 2, 3, 4, Free, Test).

1.3.1.2 - TOT CNT DISPLAY

1.3.1.2

DISPLAYING THE TOTAL COUNTERS

This function is used for displaying the total counters regarding each selection.

1.3.1.3 - SEL.NO.CNT. DIS.

1.3.1.3

DISPLAYING THE SELECTION COUNTERS IN NORMAL VENDING - /MAINTENANCE

This function is used for displaying the total counters regarding the selections made while in normal vending mode and maintenance mode.

1.3.2 - DISPLAY BAND CNT

1.3.2

DISPLAYING THE TIME BAND COUNTERS

When selecting the desired price band (0, 1, 2, 3, 4, Free, Test), the total number of selections made for that price band is displayed.

1.3.3 - DISC. CNT. DISP.

1.3.3

DISPLAYING THE DISCOUNT COUNTERS

This function is used for displaying the total amount of discounts and overprice accumulated for the dispensed selections.

FILLER MENU

1.3.4 - FAIL. CNT. DISP.

1.3.4

DISPLAYING THE FAILURE COUNTERS

This function is used for displaying the number of times each possible failure occurred in the vending machine.

1.3.5 - COIN MECH. DISP.

1.3.5

DISPLAYING THE COIN MECHANISM DATA

1.3.5.1 - AUDIT DATA DISP.

1.3.5.1

DISPLAYING THE AUDIT DATA

This function is used for displaying the number of coins inserted in the vending machine, differentiated by the type of coin.

1.3.5.2 - CASH COUNT. DISP.

1.3.5.2

DISPLAYING THE CASHED AMOUNT

This function is used for displaying the value of:

- Total cashed
- Total sold
- Total cashed by credit

1.4 - DISP. REL. STAT.

1.4

DISPLAYING THE RELATIVE STATISTICS

1.4.1 - SEL. CNT. DISP.

1.4.1

DISPLAYING THE SELECTION COUNTERS

1.4.1.1 - CNT DIS. X S.SEL

1.4.1.1

DISPLAYING THE SINGLE COUNTERS

This function is used for displaying the counters regarding each selection, divided by price band (0, 1, 2, 3, 4, Free, Test).

1.4.1.2 - TOT CNT DISPLAY

1.4.1.2

DISPLAYING THE TOTAL COUNTERS

This function is used for displaying the total counters regarding each selection.

FILLER MENU

1.4.1.3 - SEL.NO.CNT. DIS.

1.4.1.3

DISPLAYING THE SELECTION COUNTERS IN NORMAL VENDING - MAINTENANCE

This function is used for displaying the total counters regarding the selections made while in normal vending mode and maintenance mode.

1.4.2 - DISPLAY BAND CNT

1.4.2

DISPLAYING THE TIME BAND COUNTERS

When selecting the desired price band (0, 1, 2, 3, 4, Free, Test), the total number of selections made for that price band is displayed.

1.4.3 - DISC. CNT. DISP.

1.4.3

DISPLAYING THE DISCOUNT COUNTERS

This function is used for displaying the total amount of discounts and overprice accumulated for the dispensed selections.

1.4.4 - FAIL. CNT. DISP.

1.4.4

DISPLAYING THE FAILURE COUNTERS

This function is used for displaying the number of times each failure occurred in the vending machine.

1.4.5 - COIN MECH. DISP.

1.4.5

DISPLAYING THE COIN MECHANISM DATA

1.4.5.1 - AUDIT DATA DISP.

1.4.5.1

DISPLAYING THE AUDIT DATA

This function is used for displaying the number of coins inserted in the vending machine, differentiated by the type of coin.

1.4.5.2 - CRSH COUNT. DIS.

1.4.5.2

DISPLAYING THE CASHED AMOUNT

This function is used for displaying the value of:

- Total cashed
- Total sold
- Total cashed by credit

1.5 - DELETE REL.STAT.

1.5

DELETING THE RELATIVE STATISTICS

FILLER MENU

1.5.1 - PARTIAL RESET

1.5.1 **PARTIAL DELETE**

1.5.1.1 - SEL. CNT. RESET

1.5.1.1 **DELETING THE SELECTION COUNTERS**

When confirming this function, the counters regarding the different selections are deleted.

1.5.1.2 - DISC. CNT. RESET

1.5.1.2 **DELETING THE DISCOUNT COUNTERS**

When confirming this function, the counters regarding discounts and overprice are deleted.

1.5.1.3 - FAIL. CNT. RESET

1.5.1.3 **DELETING THE FAILURE COUNTERS**

When confirming this function, the counters regarding the different failure are deleted.

1.5.1.4 - COIN MECH. RESET

1.5.1.4 **DELETING THE COIN MECHANISM DATA**

When confirming this function, the counters regarding the coin mechanism data are deleted.

1.5.2 - TOTAL RESET

1.5.2 **TOTAL DELETE**

When confirming this function, all relative statistics are deleted.

FILLER MENU

2 - SET INDIV. PRICE

2 **SETTING SINGLE PRICES**

This function is used for setting a different price for each selection.

2.1 - PRICE BAND 0

2.1 **PRICE BAND 0**

This function is used for setting the sales price for each selection during time band 0.

2.2 - PRICE BAND 1

2.2 **PRICE BAND 1**

This function is used for setting the sales price for each selection during time band 1 (if set).

2.3 - PRICE BAND 2

2.3 **PRICE BAND 2**

This function is used for setting the sales price for each selection during time band 2 (if set).

2.4 - PRICE BAND 3

2.4 **PRICE BAND 3**

This function is used for setting the sales price for each selection during time band 3 (if set).

2.5 - PRICE BAND 4

2.5 **PRICE BAND 4**

This function is used for setting the sales price for each selection during time band 4 (if set).

FILLER MENU

3 - TUBE CONTROL

3

CHANGE TUBES CONTROL

3.1 - FILLING TUBE

3.1

FILLING THE CHANGE TUBES

From this function, the change tubes can be filled manually. Confirming the refilling, the display will indicate "Credit: —" which is the value of money available in change the tubes; insert the desired coin into the validator and the display will indicate the value of money available in the change tubes.

3.2 - TUBE EMPTYING

3.2

RELEASING THE CHANGE TUBES

From this function, the change tubes can be released manually. When confirming the releasing, it will be possible to decide which tube to release. Each time the confirm button is pressed, a coin is ejected from the active tube.

4 - BOILERS TEMPER.

4

BOILER TEMPERATURE

This function is used for displaying the operating temperature, expressed in °C, of the boilers actually installed in the machine.

5 - TEST

5

TEST

5.1 - COMP. DISPENSING

5.1

COMPLETE DISPENSING

With this function it is possible to obtain, with the door open and without inserting any money, complete dispensing for each selection.

5.2 - WATER ONLY

5.2

WATER ONLY

With this function it is possible to dispense, with the door open and without inserting any money, only the water doses for each selection.

5.3 - POWDER ONLY

5.3

POWDER ONLY

With this function it is possible to dispense, with the door open and without inserting any money, only the powder doses for each selection.

FILLER MENU

6 - GSM

6 GSM

6.1 - RES PRE-ALM CNT.

6.1 RESETTING THE PRE-ALARM COUNTERS

With this function the counters that control the pre-alarms are reset.

7 - EVADTS

7 EVADTS

7.1 - CONNECTION

7.1 CONNECTION

This function places the machine in wait mode for connection to retrieve data.

TECHNICIAN MENU

1 - FAILURES

1.1 - FAILURE READING

NO WATER

WASTE CONT. FULL

AIR-BREAK

VOLUM. COUNTER

INSTANT BOILER

MACHINE CONTROL BOARD

1. FAILURES

1.1 READING THE FAILURES

When the “Failure” function is displayed, press the confirm button “” to display the present failures.

If no failures are currently present, after pressing the confirm button “” the message “End failures” will be displayed.

The possible failures are indicated in the following cases:

Water failure

If the air-break micro-switch is closed for more than one minute, the water inlet solenoid valve will remain energized until the water flow is restored.

If the machine is equipped with an internal water supply tank the pump will be switched off.

Waste container full

The espresso coffee based selections are disabled when reaching the number of used coffee doses that the solid waste tray can hold.

Air-break

The machine is locked if after 10 selections the micro-switch has never signalled the lack of water.

Volumetric Counter

The machine is locked in the event of failed computation of the volumetric counter (flow-meter) within a max. given time.

Instant Boiler

The machine will lock if after 20 minutes of heating from the machine start, or from the last selection, the instant boiler fails to reach the operating temperature set at point 2.3.1 of the Technician Menu.

Machine control board

The machine will lock in the event of failed communication between C.P.U. board and machine control board.

TECHNICIAN MENU

COIN MECHANISM

Coin mechanism

The machine is locked if it receives a pulse longer than 2 seconds on a validator line or the communication with the serial coin mechanism does not take place for more than 30 seconds (Executive) or 75 seconds (BDV).

MACHINE LOCK

Machine lock

The machine is locked if when reaching the number of selections set at point 2.3.B of the Technician Menu.

RELEASE COFFEE

Coffee release

If after releasing the ground coffee dose the micro-switch of the coffee doser unit indicates the presence of coffee in the dosing chamber, all coffee-based selections are disabled.

ESPRESSO UNIT

Espresso unit

Due to mechanical blocking of the coffee unit. The machine is not locked, but the espresso coffee-based selections are disabled.

NO COFFEE

No coffee

If the coffee grinder speed exceeds the value of 1200 rpm for longer than 5 seconds the “no coffee” failure is registered. It is possible to enable this type of warning and disable the coffee-based selections in the function “Enable no coffee” of the Technician Menu.

GRINDER

Grinder blocked

If the coffee grinder does not rotate or rotates too slowly, the espresso coffee-based selections are disabled; however, the decaffeinated coffee-based selections remain available.

RAM DATA

RAM Data

One or more areas of the RAM contain wrong data which was corrected with the default values.

The machine will continue to function, but it would be advisable to initialise as soon as possible.

ESPRESSO BOILER

Espresso boiler

The machine will lock if after 10 minutes of heating from the machine start, or from the last selection, the instant boiler fails to reach the operating temperature set at point 2.3.1 of the Technician Menu.

TECHNICIAN MENU

FB 1/2 PISTON

Fresh Brew piston

It is due to wrong positioning of the unit. The machine is not locked, but all fresh product based selections are disabled.

FB 1/2 SCRAPER

Fresh Brew scraper

Wrong positioning of the grounds ejection scraper. The machine is not locked, but all fresh product based selections are disabled.

COFFEE SEL. OUT

Espresso lock

The machine is locked if when reaching the number of espresso coffee-based selections set separately at point 2.3.B of the Technician Menu.

INSTANTS UNAVAIL

Instant prod. lock

The machine is locked if when reaching the number of instant product-based selections set separately at point 2.3.B of the Technician Menu.

VUOTO CALDAIA V

Steam boiler failure

The machine does not dispense the milk-based selections or hot water if the presence of water in the steam boiler is not signalled. The boiler heating is disabled.

If after 30 minutes from the machine power on or 10 minutes from the last selection the steam boiler does not reach the operating temperature, the milk-based selections are blocked.

1.2 - FAILURE RESET

1.2

RESETTING THE FAILURES

By confirming this function all current failures will be reset

1.3 - V.A.NEON 0.OF 5.

1.3

FLUORESCENT LAMPS SWITCHED OFF

This function is used for setting whether or not the lighting lamps in the external panels are to be switched on when the machine is out of service or during the "Energy saving" time band.

TECHNICIAN MENU

2 - SET PARAMETERS

2 **SETTING THE PARAMETERS**

2.1 - CASH

2.1 **CASH**

This set of functions controls all parameters regarding the payment systems and the sales prices.

2.1.1 - PRICES

2.1.1 **PRICES**

Four different prices can be set for each selection according to the programmed time bands for when the time table option is enabled. For each of the 4 time bands prices (0 to 65,535) can be programmed globally (same price for all selections) or for the single selections.

Should the majority of products be sold at the same price, it will be convenient to set the price globally and then change the figure of the selections with different prices.

2.1.1.1 - SET INDIV. PRICE

2.1.1.1 **SETTING SINGLE PRICES**

This function is used for setting a different price for each selection in each price band that was set.

2.1.1.1.1 - PRICE BAND 0

2.1.1.1.1 **PRICE BAND 0**

The price of time band 0 can be set for each selection.

2.1.1.1.2 - PRICE BAND 1

2.1.1.1.2 **PRICE BAND 1**

The price of time band 1 can be set for each selection.

2.1.1.1.3 - PRICE BAND 2

2.1.1.1.3 **PRICE BAND 2**

The price of time band 2 can be set for each selection.

TECHNICIAN MENU

2.1.1.1.4 - PRICE BAND 3

2.1.1.1.4 PRICE BAND 3

The price of time band 3 can be set for each selection.

2.1.1.1.5 - PRICE BAND 4

2.1.1.1.4 PRICE BAND 4

The price of time band 4 can be set for each selection.

2.1.1.2 - SET GLOB. PRICES

2.1.1.2 SETTING GLOBAL PRICES

This function is used for setting one price for all available selections.

2.1.1.2.1 - PRICE BAND 0

2.1.1.2.1 PRICE BAND 0

The price of time band 0 can be set for all selections.

2.1.1.2.2 - PRICE BAND 1

2.1.1.2.2 PRICE BAND 1

The price of time band 1 can be set for all selections.

2.1.1.2.3 - PRICE BAND 2

2.1.1.2.3 PRICE BAND 2

The price of time band 2 can be set for all selections.

2.1.1.2.4 - PRICE BAND 3

2.1.1.2.4 PRICE BAND 3

The price of time band 3 can be set for all selections.

2.1.1.2.5 - PRICE BAND 4

2.1.1.2.5 PRICE BAND 4

The price of time band 4 can be set for all selections.

TECHNICIAN MENU

2.1.1.3 - TIME SCHEDULE

2.1.1.3

TIME BANDS

Four programmable time bands are provided for selling products at different prices.

Time band 0 is not programmable and covers the 24 hours.

2.1.1.3.1 - SET DATE & TIME

2.1.1.3.1

SET DATE AND TIME

This function is used for setting the reference time given by an internal clock programmable for:

day/month/year/week-day 1-7 (1=Monday, 2=Tuesday, etc...) and then hour/minutes/seconds.

2.1.1.3.2 - TIME BAND 1

2.1.1.3.2

TIME BAND 1

The time bands are programmable for beginning and end time by hours (00 to 23) and minutes (00 to 59). If the values for start and end of the time band are set to 00.00 the time period is disabled.

2.1.1.3.3 - TIME BAND 2

2.1.1.3.3

TIME BAND 2

The time bands are programmable for beginning and end time by hours (00 to 23) and minutes (00 to 59). If the values for start and end of the time band are set to 00.00 the time period is disabled.

2.1.1.3.4 - TIME BAND 3

2.1.1.3.4

TIME BAND 3

The time bands are programmable for beginning and end time by hours (00 to 23) and minutes (00 to 59). If the values for start and end of the time band are set to 00.00 the time period is disabled.

2.1.1.3.5 - TIME BAND 4

2.1.1.3.5

TIME BAND 4

The time bands are programmable for beginning and end time by hours (00 to 23) and minutes (00 to 59). If the values for start and end of the time band are set to 00.00 the time period is disabled.

TECHNICIAN MENU

2.1.2 - COIN MECHANISM

2.1.2.1 - COIN MECH. SET.

VALIDATORI

BDV

2.1.2 COIN MECHANISMS

2.1.2.1 SETTING THE COIN MECHANISMS

It is possible to decide which of the payment system protocols available are to be enabled for the functions.

The available payment systems are:

- Executive
- Validators
- BDV
- MDB

By selecting one of the systems it is possible to control its functions.

Executive

The following payments systems are available for the Executive system:

- Standard
- Price Holding
- Coges
- U-Key
- Sida

Validators

When the "Validator Lines" function (line programming) of the "programming" menu is displayed, the value of the 6 Validator coin lines, A to F, can be changed.

BDV

The BDV protocol menus are used for defining the following functions:

Type of vending

Setting the operating mode for multiple or single dispensing. With multiple dispensing, the change is not automatically returned after a successful selection; however the credit is available for further selections. When pressing the coin return button, the available credit is returned if its value is lower than the maximum change value.

Change control

This function enables/disables the return of credit if no selections are made.

If enabled, this function allows the return of coins even if the first selection was not dispensed.

If however a selection fails for any reason, the change will be returned if requested.

Maximum credit

This function is used to define the maximum accepted credit.

Maximum change

It is possible to set a limit to the total amount of change returned by the coin mechanism when pressing the coin return button or after a single dispensing serving.

Any credit exceeding the amount programmed with this function will be cashed.

Accepted coins

It is possible to define which, among the coins recognised by the validator, are to be accepted.

Check the label on the coin mechanism for the correct coin to value matching, indicating the position of the coins.

TECHNICIAN MENU

Not accepted coins

This function programs the rejection of coins when in “exact amount” mode.

Check the label on the coin mechanism for the correct coin to value matching, indicating the position of the coins.

Dispensing buttons

This function enables or not the buttons on the coin mechanism used to release the coins in the change return tubes.

Value of “exact amount”

This value defines the combination of empty coin tubes, setting the coin mechanism in “exact amount” mode. The possible combinations of empty coin tubes are indicated below.

For greater simplicity, the combination is described with reference to tubes A, B and C, where tube A receives the lower value coins and tube C the greater value coins.

0	=	A or (B and C)
1	=	A and B and C
2	=	A and B only
3	=	A and (B or C)
4	=	A only
5	=	A or B only (default)
6	=	A or B or C
7	=	A or B only
8	=	A or C only
9	=	B and C only
10	=	B only
11	=	B or C only
12	=	C only

C.P.C. device

It dialogues with the coin mechanism if devices are installed or removed from the serial interface (C.P.C.-type devices - the monitoring unit is always enabled by default).

Minimum level of tubes

It brings forward the “Insert exact amount” message for the user, by adding a number of coins between 0 and 15 to the programmed number of coins, to set the “full change tubes” status.

Free Vend VMC

Most payment systems with the BDV protocol control the free vend function.

However, there are some payment systems without such function. In this case, if free selections are to be dispensed, free vending must be enabled with VMC (vending machine control, enabled by default) and the price of the selections must be set to zero.

MDB

The MDB protocol menus are used for defining the following functions:

Type of vending

Setting the operating mode for multiple or single dispensing. With multiple dispensing, the change is not automatically returned after a successful selection; however the credit is available for further selections. When pressing the coin return button (if the function is enabled), the available credit is returned up to the maximum change value.

Change control

To enable/disable the operation of the coin return button.

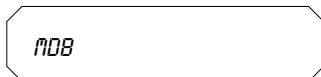

TECHNICIAN MENU

Maximum credit

This function is used to define the maximum accepted credit.

Maximum change

It is possible to set a limit to the total amount of change returned by the coin mechanism when pressing the coin return button or after a single dispensing serving.

Any credit exceeding the amount programmed with this function will be cashed.

Accepted coins

It is possible to define which, among the coins recognised by the validator, are to be accepted when the change tubes are full.

Check the coin mechanism configuration for the correct coin to value matching.

Returned coins

It is possible to define which, among the coins available in the tubes, are to be used for returning the change. This parameter is active only with coin mechanisms that do not automatically control the choice of tube to be used (Auto changer payout).

Check the coin mechanism configuration for the correct coin to value matching.

Accepted bills

It is possible to define which, among the bills recognised by the reader, are to be accepted.

Check the reader configuration for the correct bill to value matching.

Minimum level of tubes

This function is used for setting the number of coins (0 to 15) to determine the status of full change tubes and the "Insert exact amount" message for the user.

Accepted coins with "exact amount"

It is possible to define which, among the coins recognised by the validator, are to be accepted when the machine is in the "exact amount" condition.

Check the coin mechanism configuration for the correct coin to value matching.

Accepted bills with "exact amount"

It is possible to define which, among the bills recognised by the acceptor, are to be accepted when the machine is in the "exact amount" condition.

Check the acceptor's configuration for the correct bill to value matching.

OFF

In the event of configuring the machine in a bank, this setting permits the control of 2 payment systems installed in 2 vending machines, so that when one payment system fails or no longer works, automatically the other payment system becomes functional for the bank of machines.

OFF

TECHNICIAN MENU

2.1.2.2 - IMMEDIATE CHANGE

2.1.2.2

IMMEDIATE CHANGE

This function is valid only in the case where a change-giver coin mechanism is installed in the machine.

Normally the amount for a selection is cashed after the machine sends the message "Selection successful", consequently the change is given at the end of dispensing the selected product.

By enabling this function, disabled by default, the cashed signal is sent at the beginning of dispensing, consequently the change owed to the user is given at the same time of dispensing the product.

2.1.3 - DECIMAL POINT

2.1.3

DECIMAL POINT

Press the confirm button " to display the position of the decimal point, i.e.:

0	decimal point disabled
1	XXX.X
2	XX.XX
3	X.XXX

Press the confirm button ", these values will start blinking and can then be modified as necessary.

2.2 - SELECTIONS

2.2

SELECTIONS

2.2.1 - SET WATER

2.2.1

SETTING THE WATER

2.2.1.1 - WATER DOSES

2.2.1.1

WATER DOSES

With this function the water doses that compose the drink can be set for each selection button.

These are expressed in:

- cc for instant products;
- fmp (number of pulses of the volumetric counter) for Espresso (coffee or tea).

The display will indicate the number of the water dose being set (water 1, water 2, etc.) and the water value blinking. In order to verify the correspondence between the water doses refer to the "Selection dose table".

TECHNICIAN MENU

2.2.1.2 - SET WHIP DOSES

2.2.1.2 **SETTING THE WHIPPER**

2.2.1.2.1 - SET WHIP DOSES

2.2.1.2.1 **SETTING THE WHIPPER DOSES**

The whipping time can be set for each selection button, for each water dose that composes such selection.

The duration can be set in two different modes:

2.2.1.2.2 - SET MODALITY

2.2.1.2.2 **SETTING THE WHIPPER MODE**

It is possible to choose between two different modes:

Absolute

i.e. independent from the solenoid valve opening time. The whipping duration is set as tenths of a second for Instant models and as volumetric counter pulses for Espresso models.

Relative

i.e. based on the difference, plus or minus, from the moment the solenoid valve closes.

The whipping duration is always expressed in tenths of a second.

2.2.1.3 - EL VALVE SETTING

2.2.1.3 **SOLENOID VALVE SETTINGS**

It is possible to set the water flow rate of the single solenoid valves expressed in cc/s (the default value setting in cc/s is indicated in the selection dose table) to calculate the amount of water to be dispensed.

2.2.1.4 - SET DRIPPING

2.2.1.4 **SETTING THE DRIPPING**

The wait time (programmable from 0 to 2000 hundredths of a second) to the emission of an "end of dispensing" warning sound can be set for each selection in order to allow the tubes to drain.

2.2.1.5 - SET STEPPED WATER

2.2.1.5 **STEPPED DISPENSING OF WATER**

This function is used for setting, for each instant product selection, the intermittence time of opening the solenoid valves, in order to adapt the effective flow to the dispensing time.

With the value set to 100 the solenoid valve is open continuously. The intermittence is programmable from 50 to 80 hundredths of a second for each second of water dispensing.

TECHNICIAN MENU

2.2.1.6 - PREBREW - Z3000V

2.2.1.6

PRE-BREWING - VARIABLE CHAMBER Z3000

2.2.1.6.1 - PREBREWING TIME

2.2.1.6.1

PRE-BREWING TIME

This function is used for setting, for each selection, the pre-brewing duration (programmable between 0 and 30 tenths of a second; 12 by default).

2.2.1.6.2 - PREBREWING VALUE

2.2.1.6.2

PRE-BREWING DOSE

This function is used for setting, for each espresso coffee-based selection, the amount of water to be dispensed for pre-brewing (programmable between 0 and 20 fmp (pulses of the volumetric counter; 20 by default)).

2.2.1.6.3 - PISTON PRESSURE

2.2.1.6.3

PRESSURIZATION

This function is used for deciding, for each espresso coffee-based selection, whether or not perform the pressurization, i.e. the pressure of the upper piston onto the coffee dose during brewing.

It is advisable to disable this function in the case of fine grinding in double espresso coffee selections.

2.2.1.7 - NOZZLE HOT WATER

2.2.1.7

HOT-WATER DISPENSING BUTTON

2.2.1.7.1 - NOZZLE HOT WATER

2.2.1.7.1

SETTING THE DISPENSING TIME

This function is used for setting the hot-water dispensing time through the special dispensing nozzle.

While dispensing hot water, this can be interrupted with the button located above the nozzle.

2.2.1.7.2 - MIXING PERC.

2.2.1.7.2

MIXING PERCENTAGE

This function is used for changing the outlet water temperature (approximately 98°C max) by controlling the flow of added cold water. The scrolling buttons are used for moving the cursor shown on the display to a greater flow (colder water) or hotter water (smaller flow).

By increasing the cold water flow, also the total amount of dispensed water increases.

TECHNICIAN MENU

2.2.2 - SET POWDER

2.2.2 **SETTING THE POWDERS**

2.2.2.1 - POWDER DOSES

2.2.2.1 **POWDER DOSES**

This function is used for setting, for each selection button, the instant product powder doses that compose the drink.

These are expressed in gr. (grams).

The display will indicate the combination of water and powder being set (water 1 - powder 1, etc.) and the powder dose value blinking. In order to verify the correct correspondence refer to the "Selection dose table".

2.2.2.2 - SET POWDER CYCLES

2.2.2.2 **SETTING THE POWDER CYCLES**

This function is used for setting, for each selection, the number of steps or the decaffeinated cycle for dispensing the powder, for the purpose of improving the appearance of the drink.

2.2.2.3 - DOSER SETTING

2.2.2.3 **SETTING THE DOSER UNITS**

This function is used for setting the flow rate of the single doser units, expressed in g/s, to calculate the amount of powder to be dispensed, for correct conversion of product dose values.

2.2.2.4 - GL. POWDER DOSES

2.2.2.4 **GLOBAL POWDER DOSES**

This function is used for programming the doses of a product "Globally", i.e. setting all selections with a single operation.

2.2.3 - SELECTION STATUS

2.2.3 **SELECTION STATUS**

Each single selection button can either be enabled or disabled.

2.2.4 - SEL. <-> BUTTON

2.2.4 **BUTTON <-> SELECTION**

This function permits the association of a selection number, indicated in the selection dose table, to a button in the direct selection keypad.

TECHNICIAN MENU

2.2.5 - 2 X BUTTON

2.2.5 **DOUBLE BUTTON**

According to the model and to the external keypad, it is possible to combine two buttons to a single selection.

2.2.6 - CHECK NO. SELEC.

2.2.6 **CHECKING THE SELECTION NUMBER**

Verifying the selection number (for direct selection models only) associated to a button.

2.2.7 - SET PROD. CODE

2.2.7 **SETTING THE PRODUCT CODE**

This function is used for assigning a 4-digit code to each selection for processing the statistics.

2.3 - MACHINE PARAM.

2.3 **MACHINE PARAMETERS**

2.3.1 - BOILERS TEMPER.

2.3.1 **BOILER TEMPERATURE**

This function is used for setting the operating temperature, expressed in °C, of the boilers actually installed in the machine. After selecting the boiler, press the confirm button “**↵**”, the temperature value on the display will start blinking and can be modified as necessary.

2.3.2 - TANK

2.3.2 **TANK**

The machine water supply can be from the mains or from an internal tank. For some applications it is also possible to use two internal tanks at the same time.

With this function it is possible to define whether the machine water supply is from the mains (tank = 0) or from the tanks (tank = 1 or 2).

2.3.3 - ENAB. WASH BUTTON

2.3.3 **ENABLING THE WASH BUTTON**

With this function it is possible to enable or disable the operation of the mixer wash button.

Normally the button is disabled.

TECHNICIAN MENU

2.3.4 - FAST CYCLES

2.3.4 FAST CYCLES

When this function is enabled, some of the time that is useful for improving the drink quality is eliminated: all products that compose the drink are dispensed at the same time, eliminating the “post-whipping” time.

2.3.5 - WATER FILTER

2.3.5 WATER FILTER

This function is used for enabling the display of the warning “Replace water filter” after a programmable number of selections. In order to reset the counter with the door closed, it will be necessary to set the Filter Reset Password to the special function of the Technician Menu.

2.3.6 - ENAB. AUTOM. WASH

2.3.6 ENABLING AUTOMATIC WASH

Option of setting the time when automatically cleaning the mixers and rotating the brewer units installed. When setting the time to 24.00 the function is disabled (default).

2.3.7 - ENERGY SAVING

2.3.7 ENERGY SAVING

This function is used for saving electric power when the machine is not in use.

2.3.7.1 - SET ENERGY SAV.

2.3.7.1 SET ENERGY SAVING

This function is used for enabling or disabling the automatic switch-off of the vending machine boiler during the time when it is believed the machine would not be used.

2.3.7.2 - ENERGY SAV. PAR.

2.3.7.2 ENERGY SAVING PARAMETERS

This function is used for setting the days of the week (1 Monday, 2 Tuesday, 3 Wednesday, etc.) and the time bands (band 1 and 2) when the boiler is to be switched off for energy saving.

2.3.8 - DEC. CYCLE

2.3.8 DECAFFEINATED CYCLE

For the purpose of improving the appearance of the drink the lyophilised instant product powder (if present) is dispensed before dispensing water into the mixer.

2.3.9 - EQ. CABINET

2.3.9 EQUIPPED BASE CABINET

When this function is enabled, the machine is configured for operation with an equipped base cabinet, i.e. with water supply from a tank inside the base cabinet and control of the liquid waste container float.

TECHNICIAN MENU

2.3.A - PREGRINDING

2.3.A PRE-GRINDING

This function is used for enabling/disabling the grinding of coffee for the next selection. This permits the reduction of dispensing time for a coffee selection. The function is disabled by default.

2.3.B - CNT MAX NUMBER

2.3.B COUNTER MAXIMUM NUMBER

This function is used for setting the maximum number of selections to be reached for the purpose of disabling the machine. The counters can be set for the following selections:

- Espresso
- Instant
- Espresso + Instant

When setting a new value for the counter, the previous count is cancelled.

This function is active if the counter reset password was set before hand.

2.3.C - EN. HEATING ES

2.3.c ESPRESSO UNIT HEATING

If the vending machine has not dispensed espresso coffee-based drinks for a certain period of time, this function enables the possibility of choosing whether or not heat the unit by dispensing a small amount of hot water.

The cycle is confirmed in normal vending mode through the illuminated buttons.

2.3.D - EN. EMPTY COFFEE

2.3.D ENABLE NO COFFEE

This function is used for enabling the “No coffee” warning through the message on the display “Insert coffee” and for disabling the coffee-based selections.

In the event more than one coffee grinder are present in the machine, they will be indicated as follows:

“M1, M2” with a bullet next to each name, the empty bullet indicates the “no coffee” status.

TECHNICIAN MENU

2.4 - DISPLAY

2.4 **DISPLAY**

2.4.1 - LANGUAGE

2.4.1 **LANGUAGE**

2.4.1.1 - FIRST LANGUAGE

2.4.1.1 **FIRST LANGUAGE**

With this function it is possible to select the language used for surfing within the programming menus and while in normal vending mode. The list of available languages is indicated in the dose table.

2.4.1.2 - SECOND LANGUAGE

2.4.1.2 **SECOND LANGUAGE**

With this function it is possible to choose whether or not showing the messages on the display in a second language among the ones provided and indicated in dose table.

The messages are displayed as an alternative to the ones in the main language.

2.4.2 - PROMO. ADVERT.

2.4.2 **PROMOTIONAL MESSAGE**



2.4.2.1 - ENABLE PR. ADV.

2.4.2.1 **ENABLING THE PROMOTIONAL MESSAGE**

This function is used for enabling or disabling a promotional message appearing on the display during the machine normal vending mode.

2.4.2.2 - SET PROMO. ADV.

2.4.2.2 **SETTING THE PROMOTIONAL MESSAGE**

This function is used for writing the 4-line promotional message; by pressing the confirm button “” the first character starts blinking; this can then be changed using the “” and “” buttons, scrolling through the available characters.

Once the message is completed, it can be stored by pressing button “”.

2.4.3 - CONTRAST CONTROL

2.4.3 **CONTRAST CONTROL**

This function is used for adjusting the LCD display contrast from 5% to 99%.

TECHNICIAN MENU

2.5 - PRE-SELECTIONS

2.5 PRE-SELECTIONS

This function is used for setting the pre-selections present in this model, enabling or disabling the pre-selection for a certain selection, changing dose and price.

An example for the first pre-selection is indicated below; the operations to be carried out are identical for each selection.

2.5.1 - HALF JUG

2.5.1 1/2 JUG

This pre-selection allows the dispensing of half a jug of the selected product in the event this selection is present in the alternative selections of the installed layout (see selection dose table).

2.5.1.1 - SELECTION ENABL.

2.5.1.1 ENABLING THE SELECTION

Press the confirm button to select the selection button for which the pre-selection is to be enabled.

2.5.1.2 - DOSE VARIATION

2.5.1.2 CHANGING THE DOSE

This function is used for changing the percentage of product dispensed with the pre-selection (function valid only for some pre-selections).

2.5.1.3 - PRICE VARIATION

2.5.1.3 CHANGING THE PRICE

This function is used for assigning a discount or overprice to the selection set with the pre-selection.

2.5.2 - JUG

2.5.2 JUG

This pre-selection allows the dispensing of a jug of the selected product in the event this selection is present in the alternative selections of the installed layout (see selection dose table).

2.5.3 - EXTRA SUGAR

2.5.3 EXTRA SUGAR

Pre-selection not available in these models.

2.5.4 - SUGAR -

2.5.4 SUGAR -

Pre-selection not available in these models.

2.5.5 - SUGAR +

2.5.5 SUGAR +

Pre-selection not available in these models.

TECHNICIAN MENU

2.5.6 - WATER +

2.5.6 WATER +

This pre-selection is used for adding a modifiable amount of water in the coffee or tea based selections.

2.5.7 - WATER -

2.5.7 WATER -

This pre-selection is used for decreasing by a modifiable amount the water in the coffee or tea based selections.

2.5.8 - STRONG

2.5.8 STRONG

This pre-selection is used for increasing the powder dose (coffee or tea only) by a modifiable amount in the selections based on these products.

2.5.9 - LIGHT

2.5.9 LIGHT

This pre-selection is used for decreasing the powder dose (coffee or tea only) by a modifiable amount in the selections based on these products.

2.5.A - COFFEE 2

2.5.A COFFEE 2

This pre-selection is used for making a coffee-based selection with the second type of available coffee (if present).

2.5.B - EXTRA MILK

2.5.B EXTRA MILK

This pre-selection is used for increasing by a modifiable amount the milk dose (powder only) in the milk-based selections.

2.5.C - MOKKA

2.5.c MOKKA

This pre-selection is used for decreasing by a modifiable amount the water dose in the coffee selections for the purpose of obtaining a "mokka" type drink.

2.5.D - SUGAR +/-

2.5.D SUGAR +/-

Pre-selection not available in these models.

2.5.E - WATER +/-

2.5.E WATER +/-

Pre-selection not available in these models.

2.5.F - POWDER +/-

2.5.F POWDER +/-

Pre-selection not available in these models.

TECHNICIAN MENU

2.6 - MISCELLANEOUS

2.6 **MISCELLANEOUS**

2.6.1 - FB DATA

2.6.1 **FRESH-BREW UNIT DATA**

2.6.1.1 - FR. BREW 1 UNIT

2.6.1.1 **FRESH BREW 1**

This function is used for setting the brewing time for the two fresh-brew unit, the drying time for the used dose and whether or not to enable product whipping and automatic washing of the brewer unit (if fitted).

2.6.1.2 - FR. BREW 2 UNIT

2.6.1.2 **FRESH BREW 2**

This function is used for setting the brewing time for the two fresh-brew unit, the drying time for the used dose and whether or not to enable product whipping and automatic washing of the brewer unit (if fitted).

2.6.2 - JUG FACILITIES

2.6.2 **JUG FACILITIES**

This function is used for setting a programmable number (1 to 9; 5 by default) of consecutive selections to fill a jug.

TECHNICIAN MENU

2.6.3 - PASSWORD

2.6.3

PASSWORD

This function is used for setting a password for accessing the "Technician menu" mode.

2.6.3.1 - SET PASSWORD

2.6.3.1

SETTING THE PASSWORD

Enter a 5-digit numeric code to be set as password.

2.6.3.2 - ENABLE PASSWORD

2.6.3.2

ENABLING THE PASSWORD

This function is used for enabling or disabling the password request when accessing the "Technician menu" mode (disabled by default).

2.6.3.3 - CNT RESET PWD

2.6.3.3

COUNTER RESET PASSWORD

This function is used for setting the password for resetting the counters set in the Technician menu 2.3.b

2.6.3.4 - JUG FACILITY PWD

2.6.3.4

JUG FACILITY PASSWORD

This function is used for setting the password for switching the machine to jug facility mode.

2.6.3.5 - FREE VENDING PWD

2.6.3.5

FREE VENDING PASSWORD

This function is used for setting the password for switching the machine to free vending mode.

2.6.3.6 - KEYPAD LOCK PWD

2.6.3.6

KEYPAD LOCK PASSWORD

This function is used for setting the password in order to lock the selection keypad until the password is entered again.

2.6.3.7 - WASH PWD

2.6.3.7

WASH PASSWORD

This function is used for setting the password that must be entered while in normal vending mode (with the door closed) for performing a mixer wash cycle.

TECHNICIAN MENU

2.6.3.8 - TEST SEL. PWD

2.6.3.8

TEST SELECTION PASSWORD

This function is used for setting the password to access the "Programming menu" mode and therefore also the test selections made from the outside.

2.6.3.9 - FILTER RESET PWD

2.6.3.9

FILTER RESET PASSWORD

This function is used for setting the password required for resetting the message "Replace water filter" with the door closed and resetting the counter after replacing the filter.

2.6.3.A - WASTE RESET PWD

2.6.3.A

WASTE TRAY RESET PASSWORD

This function is used for setting the password for resetting the selection counters of the machine lock function for "Waste tray full"

2.6.4 - ENABLE FILL MENU

2.6.4

ENABLING THE FILLER MENU

This function is used for determining which of the "Filler menu" functions are to be left active and which are to be disabled. The reference numbers of the menus do not change even if some are disabled.

2.6.5 - ES UNIT

2.6.5

ESPRESSO UNIT

This function is used for setting the standby position of the Z3000 espresso unit.

- OPEN brewing chamber open;
- CLOSED brewing chamber closed.

By default the position is set to OPEN.

2.6.6 - AUT. UNIT WASH

2.6.6

AUTOMATIC UNIT WASH

This function is used for setting the daily unit wash of the espresso unit by setting the time when it is to be performed. If setting the time to 00.00 the function is disabled.

TECHNICIAN MENU

3 - STATISTICS

3 **STATISTICS**

3.1 - ELECTR. COUNTER

3.1 **ELECTRONIC COUNTER**

3.1.1 DISPLAY COUNTERS

3.1.1 **DISPLAYING THE SELECTION COUNTERS**

This function is used for displaying the total number of selections dispensed by the vending machine.

3.1.2 - RESET COUNTER

3.1.2 **RESETTING THE COUNTERS AT POWER-ON**

This function is used for resetting the general selection counter.

3.2 - STATIST. DISPLAY

3.2 **DISPLAYING THE STATISTICS**

3.2.1 - SEL. CNT. DISP.

3.2.1 **DISPLAYING THE SELECTION COUNTERS**

3.2.1.1 - CNT DIS. X 5 SEL

3.2.1.1 **DISPLAYING THE SINGLE COUNTERS**

This function is used for displaying the counters regarding each selection, divided by price band (0, 1, 2, 3, 4, Free, Test).

3.2.1.2 - TOT CNT DISPLAY

3.2.1.2 **DISPLAYING THE TOTAL COUNTERS**

This function is used for displaying the total counters regarding each selection.

3.2.1.3 - SEL.NO.CNT. DIS.

3.2.1.3 **DISPLAYING THE SELECTION COUNTERS IN NORMAL VENDING - MAINTENANCE**

This function is used for displaying the total counters regarding the selections made while in normal vending mode and maintenance mode.

TECHNICIAN MENU

3.2.2 - DISPLAY BAND CNT

3.2.2

DISPLAYING THE TIME BAND COUNTERS

When selecting the desired price band (0, 1, 2, 3, 4, Free, Test), the total number of selections made for that price band is displayed.

3.2.3 - DISC. CNT. DISP.

3.2.3

DISPLAYING THE DISCOUNT COUNTERS

This function is used for displaying the total amount of discounts and overprice accumulated for the dispensed selections.

3.2.4 - FAIL. CNT. DISP.

3.2.4

DISPLAYING THE FAILURE COUNTERS

This function is used for displaying the number of times each possible failure occurred in the vending machine.

3.2.5 - COIN MECH. DISP.

3.2.5

DISPLAYING THE COIN MECHANISM DATA

3.2.5.1 - AUDIT DATA DISP.

3.2.5.1

DISPLAYING THE AUDIT DATA

This function is used for displaying the number of coins inserted in the vending machine, differentiated by the type of coin.

3.2.5.2 - CASH COUNT. DIS.

3.2.5.2

DISPLAYING THE CASHED AMOUNT

This function is used for displaying the value of:

- Total cashed
- Total sold
- Total cashed by credit

TECHNICIAN MENU

3.3 - STATISTICS RESET

3.3
DELETING THE STATISTICS

3.3.1 - PARTIAL RESET

3.3.1
PARTIAL DELETE

3.3.1.1 - SEL. CNT. RESET

3.3.1.1
DELETING THE SELECTION COUNTERS

When confirming this function, the counters regarding the different selections are deleted.

3.3.1.2 - DISC. CNT. RESET

3.3.1.2
DELETING THE DISCOUNT COUNTERS

When confirming this function, the counters regarding discounts and overprice are deleted.

3.3.1.3 - FAIL. CNT. RESET

3.3.1.3
DELETING THE FAILURE COUNTERS

When confirming this function, the counters regarding the different failure are deleted.

3.3.1.4 - COIN MECH. RESET

3.3.1.4
DELETING THE COIN MECHANISM DATA

When confirming this function, the counters regarding the coin mechanism data are deleted.

3.3.2 - TOTAL RESET

3.3.2
TOTAL DELETE

When confirming this function, all statistics are deleted.

TECHNICIAN MENU

3.4 - DISP. REL. STAT.

3.4 **DISPLAYING THE RELATIVE STATISTICS**

3.4.1 - SEL. CNT. DISP.

3.4.1 **DISPLAYING THE SELECTION COUNTERS**

3.4.1.1 - CNT DIS. X 5 SEL

3.4.1.1 **DISPLAYING THE SINGLE COUNTERS**

This function is used for displaying the counters regarding each selection, divided by price band (0, 1, 2, 3, 4, Free, Test).

3.4.1.2 - TOT CNT DISPLAY

3.4.1.2 **DISPLAYING THE TOTAL COUNTERS**

This function is used for displaying the total counters regarding each selection.

3.4.1.3 - SEL.NO.CNT. DIS.

3.4.1.3 **DISPLAYING THE SELECTION COUNTERS IN NORMAL VENDING - MAINTENANCE**

This function is used for displaying the total counters regarding the selections made while in normal vending mode and maintenance mode.

3.4.2 - DISPLAY BAND CNT

3.4.2 **DISPLAYING THE TIME BAND COUNTERS**

When selecting the desired price band (0, 1, 2, 3, 4, Free, Test), the total number of selections made for that price band is displayed.

3.4.3 - DISC. CNT. DISP.

3.4.3 **DISPLAYING THE DISCOUNT COUNTERS**

This function is used for displaying the total amount of discounts and overprice accumulated for the dispensed selections.

3.4.4 - FAIL. CNT. DISP.

3.4.4 **DISPLAYING THE FAILURE COUNTERS**

This function is used for displaying the number of times each possible failure occurred in the vending machine.

TECHNICIAN MENU

3.4.5 - COIN MECH. DISP.

3.4.5

DISPLAYING THE COIN MECHANISM DATA

3.4.5.1 - AUDIT DATA DISP.

3.4.5.1

DISPLAYING THE AUDIT DATA

This function is used for displaying the number of coins inserted in the vending machine, differentiated by the type of coin.

3.4.5.2 - CASH COUNT. DIS.

3.4.5.2

DISPLAYING THE CASHED AMOUNT

This function is used for displaying the value of:

- Total cashed
- Total sold
- Total cashed by credit

TECHNICIAN MENU

3.5 - DELETE REL.STAT.

3.5
DELETING THE RELATIVE STATISTICS

3.5.1 - PARTIAL RESET

3.5.1
PARTIAL DELETE

3.5.1.1 - SEL. CNT. RESET

3.5.1.1
DELETING THE SELECTION COUNTERS

When confirming this function, the counters regarding the different selections are deleted.

3.5.1.2 - DISC. CNT. RESET

3.5.1.2
DELETING THE DISCOUNT COUNTERS

When confirming this function, the counters regarding discounts and overprice are deleted.

3.5.1.3 - FAIL. CNT. RESET

3.5.1.3
DELETING THE FAILURE COUNTERS

When confirming this function, the counters regarding the different failure are deleted.

3.5.1.4 - COIN MECH. RESET

3.5.1.4
DELETING THE COIN MECHANISM DATA

When confirming this function, the counters regarding the coin mechanism data are deleted.

3.5.2 - TOTAL RESET

3.5.2
TOTAL DELETE

When confirming this function, all relative statistics are deleted.

3.6 - EN. CNT AT START

3.6
ENABLING THE COUNTERS AT POWER-ON

By enabling this function, it is possible to display the total counters when the machine is switched on.

TECHNICIAN MENU

3.7 - STATIS. PRINTING

3.7
PRINTING THE STATISTICS

3.7.1 - PARTIAL PRINTING

3.7.1
PARTIAL PRINTOUT

3.7.1.1 - SEL. CNT. PRINT.

3.7.1.1
PRINTING THE SELECTION COUNTERS

When confirming this function, the counters regarding the different selections are printed.

3.7.1.2 - PRINT BAND CNT

3.7.1.2
PRINTING THE TIME BAND COUNTERS

When confirming this function, the counters regarding the different time bands are printed.

3.7.1.3 - DISC. CNT.PRINT.

3.7.1.3
PRINTING THE DISCOUNT COUNTERS

When confirming this function, the counters regarding discounts and overprice are printed.

3.7.1.4 - FAIL. CNT.PRINT.

3.7.1.4
PRINTING THE FAILURE COUNTERS

When confirming this function, the counters regarding the different failure are printed.

3.7.1.5 - COIN MECH. PRINT

3.7.1.5
PRINTING THE COIN MECHANISM DATA

When confirming this function, the counters regarding the coin mechanism data are printed.

3.7.2 - TOTAL PRINTING

3.7.2
TOTAL PRINTOUT

When confirming this function, all statistics are printed.

TECHNICIAN MENU

3.8 - PRINT REL. STAT.

3.8
PRINTING THE RELATIVE STATISTICS

3.8.1 - PARTIAL PRINTING

3.8.1
PARTIAL PRINTOUT

3.8.1.1 - SEL. CNT. PRINT.

3.8.1.1
PRINTING THE SELECTION COUNTERS

When confirming this function, the relative counters regarding the different selections are printed.

3.8.1.2 - PRINT BAND CNT

3.8.1.2
PRINTING THE TIME BAND COUNTERS

When confirming this function, the relative counters regarding the different time bands are printed.

3.8.1.3 - DISC. CNT.PRINT.

3.8.1.3
PRINTING THE DISCOUNT COUNTERS

When confirming this function, the relative counters regarding discounts and overprice are printed.

3.8.1.4 - FAIL. CNT.PRINT.

3.8.1.4
PRINTING THE FAILURE COUNTERS

When confirming this function, the relative counters regarding failures are printed.

3.8.1.5 - COIN MECH. PRINT

3.8.1.5
PRINTING THE COIN MECHANISM DATA

When confirming this function, the relative counters regarding the coin mechanism data are printed.

3.8.2 - TOTAL PRINTING

3.8.2
TOTAL PRINTOUT

When confirming this function, all relative statistics are printed.

TECHNICIAN MENU

4 - TEST

4. TEST

4.1 - TEST DISPENSING

4.1 TEST DISPENSING

4.1.1 - COMP. DISPENSING

4.1.1 COMPLETE DISPENSING

With this function it is possible to obtain, with the door open and without inserting any money, complete dispensing for each selection.

4.1.2 - WATER ONLY

4.1.2 DISPENSING WATER ONLY

With this function it is possible to dispense, with the door open and without inserting any money, only the water doses for each selection.

4.1.3 - POWDER ONLY

4.1.3 DISPENSING POWDER ONLY

With this function it is possible to dispense, with the door open and without inserting any money, only the powder doses for each selection.

4.2 - SPECIAL FUNCT.

4.2 SPECIAL FUNCTIONS

4.2.1 - ESPR. UNIT ROTAT.

4.2.1 UNIT ROTATION

This function is used for operating the espresso brewer unit (if fitted).

4.2.2 - RELEASE DOSE

4.2.2 RELEASING A DOSE

This function is used for starting the grinder e release a coffee dose.

4.2.3 - EMPTY ES. BOILER

4.2.3 EMPTYING THE BOILER

This function is used for opening a solenoid valve to allow the intake of air in the event of emptying the boiler for maintenance.

TECHNICIAN MENU

4.2.4 - MANUAL INSTALL.

4.2.4

MANUAL INSTALLATION

This function is used for manually installing the boilers and filling the water system.

4.3 - AUTOTEST

4.3

AUTOTEST

This function allows testing, in a semiautomatic way, of the main machine components.

It is possible to cancel each operation and go to the next one by pressing the exit button, but confirming with the confirm button to start the autotest routine.

Some checks occur automatically, others need the manual operation of the monitored component.

In a sequence:

- the steam exhaust fan is activated for a few seconds
- the doser units are activated for 2 seconds
- the mixers are activated for 2 seconds
- (only for the brewer units that are actually present) the brewer unit is rotated (grinding for the espresso brewers) and a coffee dose is dispensed
- waste tray button; the machine waits until the waste tray is re-inserted or the button is pressed manually
- espresso safety switch test; the machine waits until the compartment is re-inserted or the button is pressed manually
- push-button panel test; the machine will indicated on the display the number and by means of illumination the button which must be pressed and awaits the actuation before going to the next button
- boiler temperature reading
- sound signal actuation
- coin mechanism test; checking that communication with the coin mechanism takes place correctly and which validator lines are set as being active (only if the coin mechanism is present and set correctly).

TECHNICIAN MENU

5 - MISCELLANEOUS

5 MISCELLANEOUS

5.1 - D.A. REGISTRY

5.1 VENDING MACHINE INFORMATION

5.1.1 - INSTALL. DATE

5.1.1 INSTALLATION DATE

This function is used for storing the current date of system as installation date of the vending machine. This date will be indicated on the statistics printout.

5.1.2 - PR. MACHINE CODE

5.1.2 SETTING THE MACHINE CODE

This function is used for changing the 8-digit numeric code identifying the machine (set to 0 by default).

5.1.3 - OPER. CODE ENTRY

5.1.3 SETTING THE OPERATOR CODE

This function is used for changing the 6-digit numeric code identifying the group of machines (set to 0 by default).

TECHNICIAN MENU

5.2 - INITIALISING DB

5.2

INITIALISING THE DATA-BASE

This function is used for “initialising” the machine, resetting all data to default values. This function should be used if there is a memory data error or when the software is replaced. Except for the general electronic counter, all statistical data is reset.

When confirming this function some parameter settings are requested, and namely:

- **COUNTRY**

Intended as type of basic doses for the different selections. The available “countries” vary according to the models.

- **LAYOUT**

A number of Button/Selection combinations to choose from is provided for each dose type model (the combinations available for each layout are indicated in the dose selection table supplied with the machine).

- **TANK**

Defining whether the water supply is:

0 - from the mains

1 - from an internal tank

2 - from two internal tanks

- **STEAM BOILER**

Defining the operation (if present) of the steam boiler:

ON - enabled

OFF - disabled

When confirming the options the message “Working” is shown on the display for a few seconds.

TECHNICIAN MENU

5.3 - EVADTS

5.3

EVADTS

The EVADTS (European Vending Association Data Transfer System) communication protocol has 2 codes for identifying the machine and for recognising the data transfer terminal.

5.3.1 - PASS CODE

5.3.1

PASS CODE

It is a four-digit alphanumeric code (0-9; A-F) that must be the same as the one in the data transfer terminal to allow its identification.

When pressing the confirm button the code is displayed as "0000" regardless of the actual value; then by pressing the confirm button the first digit will start blinking.

Using the scrolling buttons, its value can be changed (during the change operation the value becomes visible).

Repeat this operation for the 4 digits, after which the value is stored and the display will indicate "0000" again.

5.3.2 - SECURITY CODE

5.3.2

SECURITY CODE

It is a further alphanumeric code for reciprocal recognition between machine and EVADTS terminal.

Programming works as in the "Pass Code".

5.3.3 - CONNECTION

5.3.3

CONNECTION

This function places the machine in wait mode for connection to retrieve data.

TECHNICIAN MENU

5.4 - UPKEY

5.4 UP-KEY

5.4.1 - SETUP MANAGEMENT

5.4.1 SETUP CONTROL

5.4.1.1 - UPKEY->MACHINE

5.4.1.1 UP-KEY -> VENDING MACHINE

When confirming this function after inserting the Up-Key in the special port located on the C.P.U. board, it will be possible to select the setup file from the list shown on the display using the scrolling buttons, then when confirming with the confirm button the selected setup will be loaded in the vending machine.

5.4.1.2 - MACHINE->UPKEY

5.4.1.2 VENDING MACHINE -> UP-KEY

When confirming this function after inserting the Up-Key in the special port located on the C.P.U. board, it will be possible to save the setup file to the Up-Key with the configuration present in that moment in the vending machine, indicating the name to be assigned to the file (e.g.: KOBALTO000.STP).

5.4.1.3 - DELETE

5.4.1.3 DELETE

This function is used for deleting one by one the setup files present in the inserted Up-Key.

5.4.1.4 - DELETE ALL

5.4.1.4 DELETE ALL

This function is used for deleting all the setup files present in the inserted Up-Key.

5.4.2 - AUDIT MANAGEMENT

5.4.2 STATISTICS MANAGEMENT

5.4.2.1 - MACHINE->UPKEY

5.4.2.1 VENDING MACHINE -> UP-KEY

When confirming this function after inserting the Up-Key in the special port located on the C.P.U. board, it will be possible to save the statistics file to the Up-Key with all of the statistics files present in that moment in the vending machine, indicating the name to be assigned to the file (e.g.: KOBALTO000.STA).

5.4.2.2 - DELETE

5.4.2.2 DELETE

This function is used for deleting one by one the statistics files present in the inserted Up-Key.

5.4.2.3 - DELETE ALL

5.4.2.3 DELETE ALL

This function is used for deleting all the statistics files present in the inserted Up-Key.

TECHNICIAN MENU

6 - GSM

6 GSM

The control software can send, via GSM modem, a signal indicating a machine failure or an “ending product” “pre-alarm”, after dispensing a certain (programmable) number of selections of a given product.

6.1 - GSM PIN CODE

6.1 GSM PIN CODE

This function is used for programming the identification code that will be sent to the GSM modem (optional) when switching the machine on.

6.2 - GSM PRE-ALARMS

6.2 GSM PRE-ALARMS

6.2.1 - SET GSM THRESH.

6.2.1 PRE-ALARMS THRESHOLDS

This function is used for defining the number of pieces or grams of powder for a given product, after which a “running-out” “pre-alarm” is signalled via modem.

6.2.2 - RES PRE-ALM CNT.

6.2.2 RESETTING THE PRE-ALARM COUNTERS

With this function the counters that control the pre-alarms are reset.

6.3 - GROUP NUMBER

6.3 BANK NUMBER

The number in the bank of machines (1 to 7) that identifies the machines that have the “slave GSM” function, therefore sending data via the “master” machine modem .

The number 0 identifies the machine that is connected directly to the modem, i.e. the “master GSM”.